

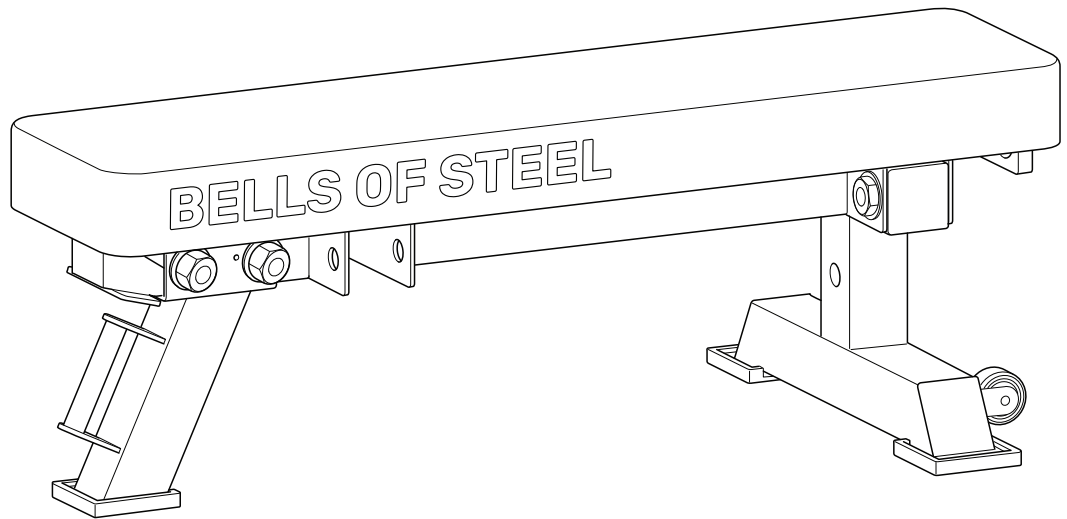

CONVERTER BENCH
FLAT DROP-IN
SKU: FLT-CNVT-BEN
PO:

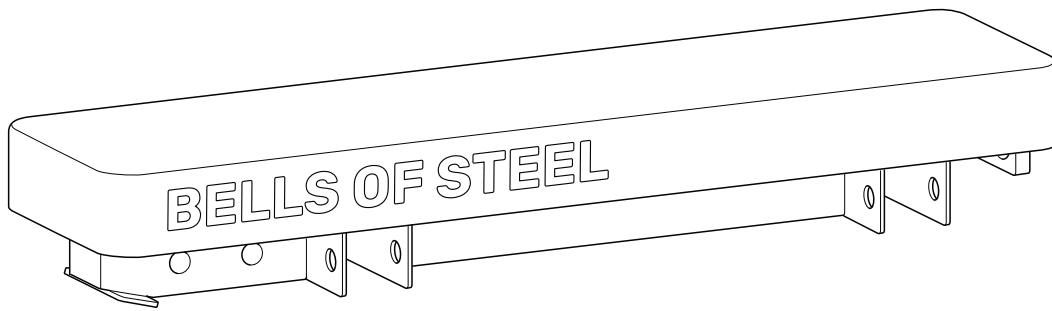

ASSEMBLY INSTRUCTIONS

   BELLSOFSTEEL

BUILDING STRENGTH, ONE BOLT AT A TIME.



Welcome to Bells of Steel, you've made an excellent choice.

First off I want to say thank you for supporting my small business.

I've put significant thought into designing this product to enhance your lifting experience and help you reach your full potential. I hope you love it!

I've done my best to keep the setup of your new gear simple. If you find yourself needing a bit more assistance than the included instructions, check our youtube page for assembly videos or feel free to email us for troubleshooting guidance.

Kaevon Khoozani



Crush your Gains! Subscribe to our YouTube for workouts & how-to's.

@BELLSOFSTEEL



Warranty & returns? We got you covered—check here:

bellssofsteel.com/pages/warranty

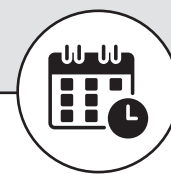

Changed your mind? No sweat. 30-day refund guarantee:

bellssofsteel.com/policies/refund-policy



Let us know how we've done

Love it? Leave a review! Hate it? We still read it. Help us get better by reviewing our products.



Customer Notice

If you are missing any parts, or otherwise have any warranty issues/shipping damages, please file a warranty claim on our website.

Before discarding the box, please take clear photos of the box and shipping labels, as these may be required if parts are missing or the item is damaged.



BELLSOFSTEEL | www.bellssofsteel.com | www.bellssofsteel.us

BEFORE WE BEGIN, LET'S STAY SAFE.



A GUIDE TO SAFETY

We know you are excited to use your new Bells of Steel gear, but please read through this Guide to Safety to ensure you do not hurt yourself or others while exercising. It is your responsibility to ensure that all users of the equipment are informed of all warnings and instructions in this manual. TO REDUCE THE RISK OF SERIOUS INJURY, READ THE FOLLOWING IMPORTANT PRECAUTIONS BEFORE USING YOUR BELLS OF STEEL PRODUCT.

- ① Before starting any exercise program consult your physician. Be aware of your body's signals. Incorrect or excessive exercise can be damaging to your health. STOP EXERCISING IF YOU EXPERIENCE ANY OF THE FOLLOWING SYMPTOMS: PAIN, TIGHTNESS IN YOUR CHEST, IRREGULAR HEARTBEAT, SHORTNESS OF BREATH, LIGHTHEADEDNESS, DIZZINESS, OR FEELINGS OF NAUSEA. IF YOU EXPERIENCE ANY OF THESE SYMPTOMS, STOP EXERCISING IMMEDIATELY AND CONSULT YOUR PHYSICIAN BEFORE CONTINUING WITH YOUR EXERCISE PROGRAM.
- ② It is your responsibility to ensure there is enough space around the product for the intended exercise. Use the product on a flat surface and ensure at least 2 feet (60 cm) of free space around it.
- ③ Children and pets must not be let on or near the product. Moving parts and heavy features of the product can be dangerous and cause serious injury.
- ④ Read all instructions in this manual before using the product and use the product only as described in this manual.
- ⑤ It is your responsibility to ensure that all users of the product are adequately informed / precautions, have read and understand all warnings, and are informed how to use the product properly.
- ⑥ Keep hands and feet from moving parts. Do not lean or rest on the product.
- ⑦ Wear athletic shoes for foot protection while exercising.
- ⑧ Your product is intended for use in cool, dry conditions. You should avoid storage in extreme cold, hot, or damp areas.
- ⑨ This product is designed for indoor use only.
- ⑩ Ensure that any weight pins that may be included with your product are completely inserted into an appropriate weight plate.
- ⑪ Ensure that any handles that may be included with your product are attached securely before using the product.
- ⑫ Ensure that any nuts and bolts that may be included with your product are securely tightened before use. Regularly re-tighten nuts and bolts.
- ⑬ Ensure any cables that may be included with your product always remain attached to their proper pulleys. If a cable bind occurs during exercise, stop immediately and inspect the part to ensure any interference is fixed.
- ⑭ Do not overexert yourself during any exercise program. Operate the product as intended.
- ⑮ The product should be anchored where required or whenever possible. The product should be secured when not in use.
- ⑯ The product is very heavy. Improper use or assembly can lead to serious injury or death.
- ⑰ SAVE AND REVIEW THESE INSTRUCTIONS.



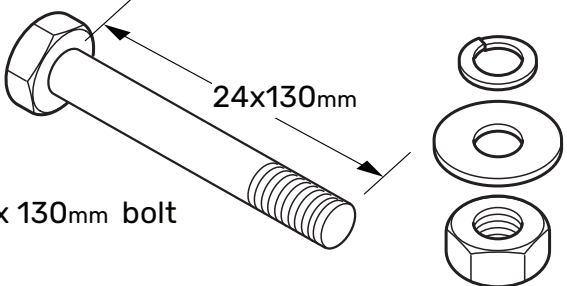
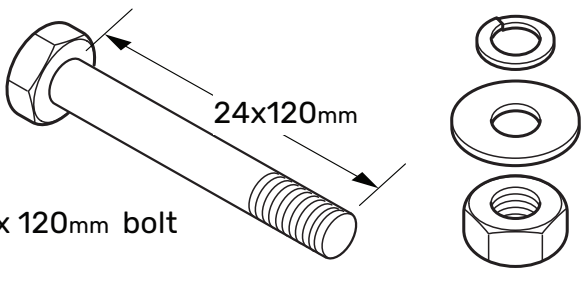
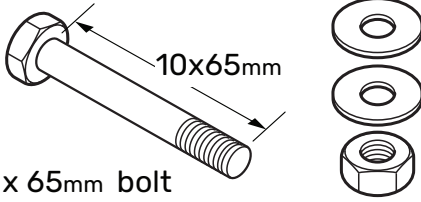
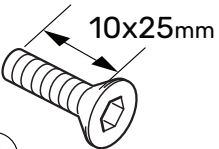
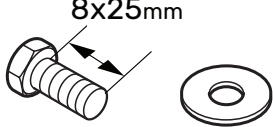

NOW...

LET THE GAINZ BEGIN

PARTS LIST

| | | |
|---|--|---|
| <p>1 M24 x 130mm bolt x2</p>  | <p>2 M24 x 120mm bolt x2</p>  | |
| <p>3 M10 x 65mm bolt x2</p>  | <p>4 M10 x 25mm screw x2</p>  | <p>5 M8 x 25mm bolt x4</p>  |

Tools required

| | | | |
|--|--|--|--|
| <p>36mm Box wrench x2</p>  | <p>17mm Box wrench x2</p>  | <p>14mm Box wrench x2</p>  | <p>6mm Hex key x1</p>  |
|--|--|--|--|

Assembly Instructions

- 1** Install the seat cushion (9) and part (6) using M8x25mm bolt, washer (5) and M10x25 bolts (4).

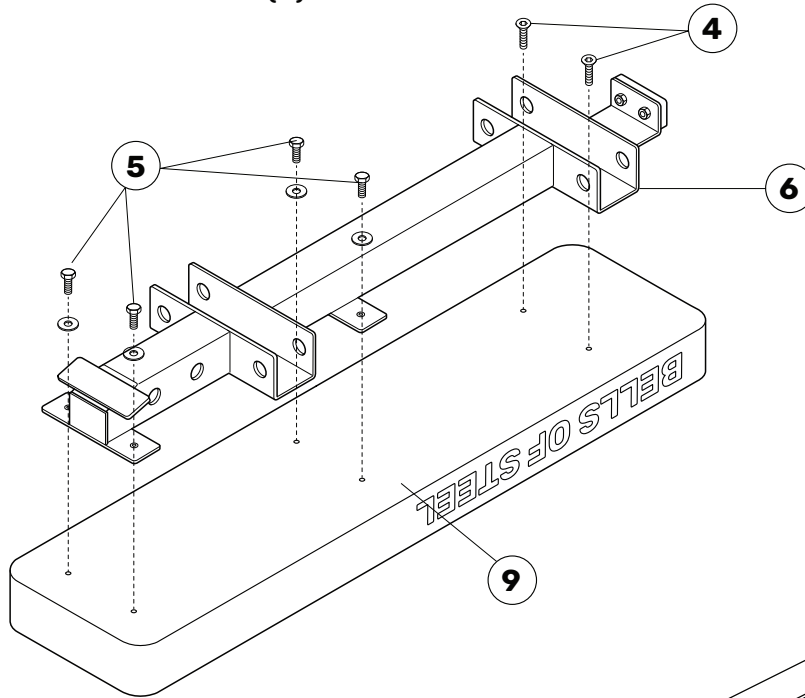

- 2** Attach parts (10) to part (8) using M10x65mm bolt, washers and nut (3)

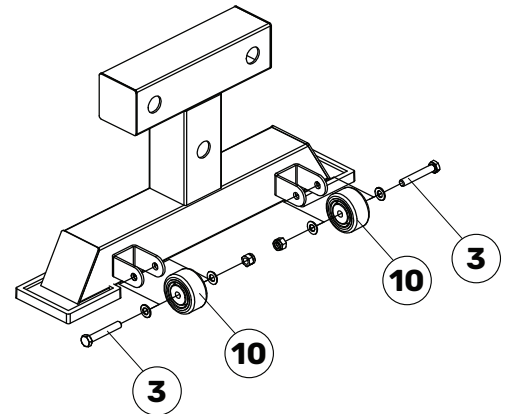

- 3** Assemble part (7) fix it with M24x130mm bolt, washers and nut (1). Next, attach part (8) using M24x120mm bolt, washers and nut (2).

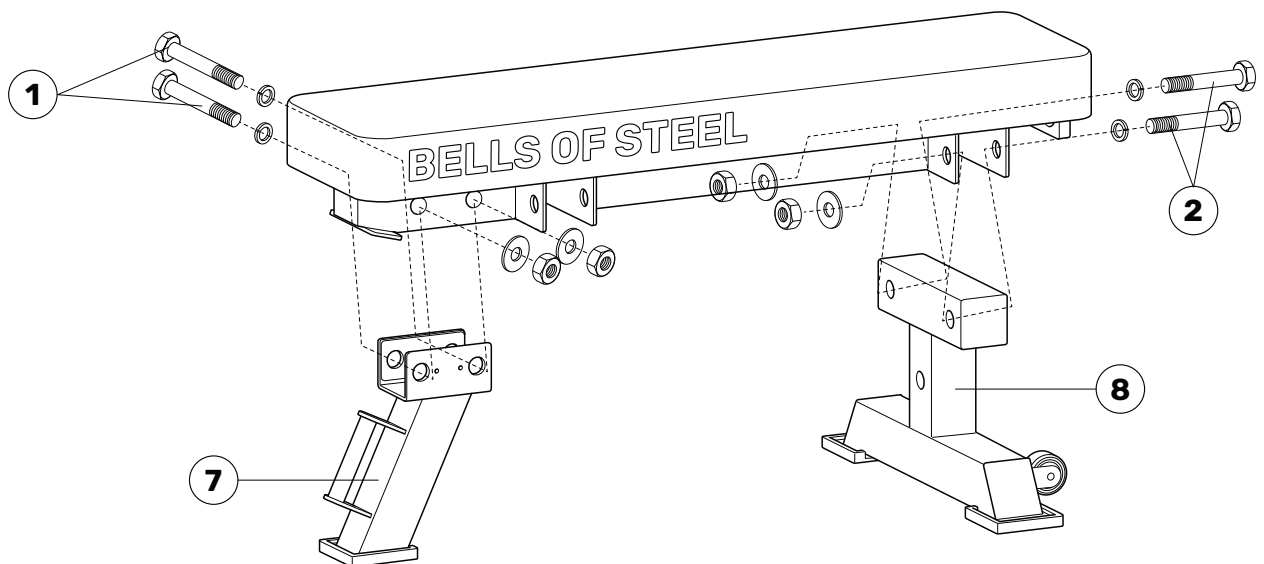

For standalone option only.

YOU'RE FINISHED!

**WANT TO LEARN MORE ABOUT THE
CONVERTER BENCH - FLAT DROP - IN
CHECK OUT THE OVERVIEW VIDEO:**



VISIT OUR SHOWROOMS



Calgary - HQ



Toronto - Showroom



Indianapolis - Showroom

Corporate Headquarters 7880 66 St SE, Calgary, AB, Canada

U.S.A. Headquarters 5925 W 71st St, Indianapolis, IN, U.S.A.

Toronto Store 39 Haist Ave # 2, Woodbridge, ON, Canada

support@bellssofsteel.com | 1-888-718-7997